

UNAUTHORIZED USE OF THIS
DRAWING IS STRICTLY PROHIBITED

DAR	REV	DESCRIPTION	APPVD	DATE
2580	A	INITIAL RELEASE	DG	7-10
4663	B	SEE DAR	DG	11-13

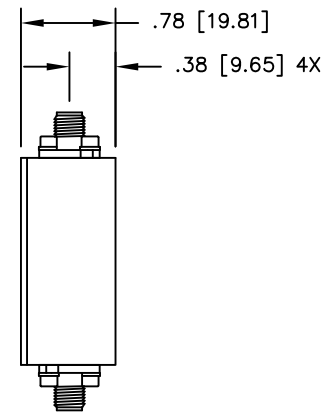
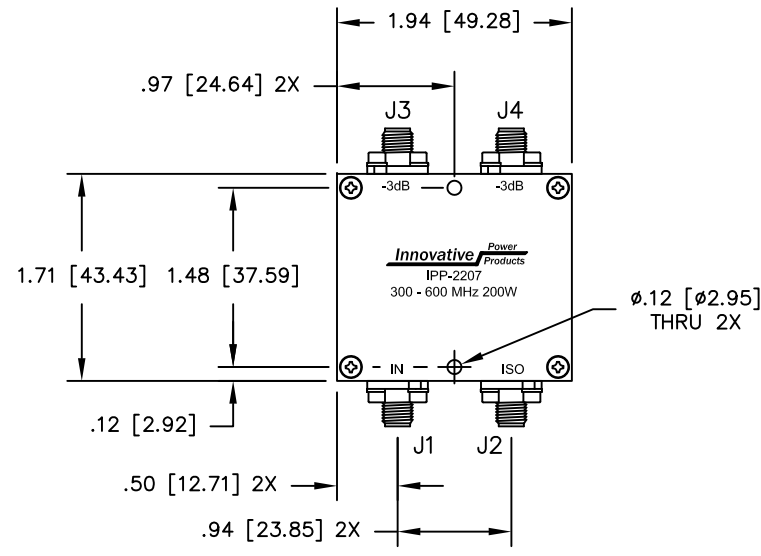

NOTES

1. SEE 90° APPLICATION NOTE FOR FURTHER INFORMATION.
2. CONNECTORS: TYPE "SMA" FEMALE.

ELECTRICAL SPECIFICATIONS

FREQUENCY:	300 – 600 MHz.
INSERTION LOSS:	< 0.5 dB
VSWR:	< 1.27:1
ISOLATION:	> 18 dB
AMPLITUDE BALANCE:	±0.65 dB
PHASE BALANCE:	±5°
POWER:	200 WATT
TEMPERATURE:	-55°C TO 85°C

PORT CONFIGURATION				
INPUT	J1	J2	J3	J4
J1	---	ISOLATION	-3dB<0 DEG	-3dB<-90 DEG
J2	ISOLATION	---	-3dB<-90 DEG	-3dB<0 DEG
J3	-3dB<0 DEG	-3dB<-90 DEG	---	ISOLATION
J4	-3dB<-90 DEG	-3dB<0 DEG	ISOLATION	---

MATERIAL AL. ALLOY, 6061-T651	DWN S.Cornell	DATE 4-2-10			
	ENG DG	DATE 5-10			
FINISH CHEM FILM, CLEAR, PER MIL-DTL-5541, TYPE 2, REV. F, CLASS 3 (ROHS COMPLIANT)	MANUF	DATE	TITLE OUTLINE, COUP., 90°, 300 - 600 MHz. 200W		
	CAGE CODE: 437R2		SIZE B	P/N	IPP-2207
TOLERANCE IN [MM]	.XX ±.02 [.50] .XXX ±.005 [.127] ANG. ±1/2°	SHEET 1 OF 1	SCALE 1:1		