

UNAUTHORIZED USE OF THIS
DRAWING IS STRICTLY PROHIBITED

DAR	REV	DESCRIPTION	APPVD	DATE
9509	A	INITIAL RELEASE	TJD	12-23
9666	B	SEE DAR	DG	4-24

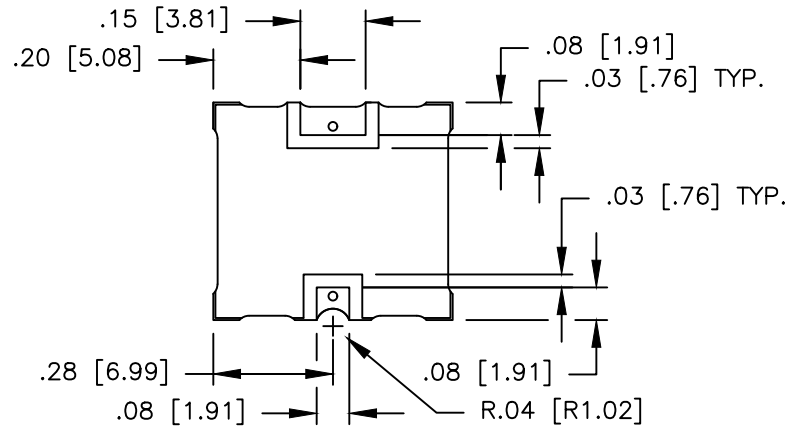
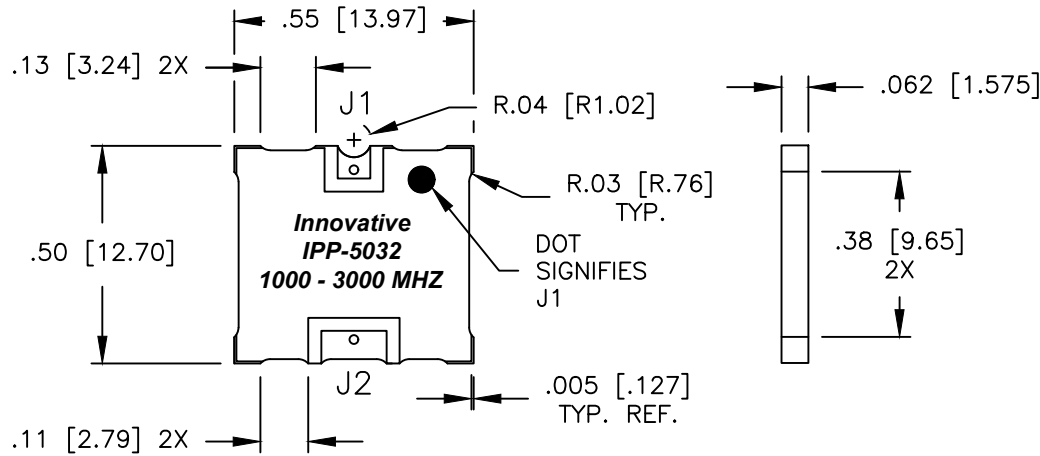

NOTES:

1. DO NOT EXCEED 250° C WHEN INSTALLING.
2. RoHS & REACH COMPLIANT.
3. AVAILABLE IN TAPE AND REEL.
4. DATA AND SPECIFICATIONS APPLY WHEN PART IS MOUNTED IN IPP TEST FIXTURE. TEST FIXTURE CONFIGURATION/FOOTPRINT AVAILABLE UPON REQUEST.

ELECTRICAL SPECIFICATIONS

FREQUENCY:	1000 - 3000 MHz.
INSERTION LOSS:	< 0.45 dB
VSWR:	< 1.35:1
POWER:	100 WATT
IMPEDANCE:	J1: 50 OHM J2: 25 OHM
TEMPERATURE:	-55°C TO 85°C

MATERIAL	DWN DG	DATE 10-23	Innovative Power® Products		
FINISH	ENG TJD	DATE 10-23			
IMMERSION TIN	MANUF	DATE	TITLE OUTLINE, SINGLE ENDED IMPEDANCE TRANSFORMER, 1000 - 3000 MHz 2:1 100 WATT		
TOLERANCE .XX ±.02 .XXX ±.010 ANG. ±1/2°	CAGE CODE: 437R2		SIZE B	P/N IPP-5032	REV. B
	SHEET 1	1	SCALE 4:1		