

# IPP High Power Resistive Products Application Note

## ❖ General Notes:

- Data and specifications apply when part is mounted in IPP test fixture.
- Conformal coating is recommended at the lead/transmission line interface for high voltage applications to prevent voltage arcing to ground.
- To insure proper grounding and heat sinking of flanged devices the bottom surface of the resistor flange or termination flange must lay flat on the mounting surface. The mounting surface must be clean and flat. A small amount of thermal grease can be applied to the bottom of the flange to insure a good thermal interface.
- Flangeless devices are designed to be soldered directly to the mounting surface/heat sink. Care should be taken not to keep the solder at melting temperature longer than necessary to make a good solder connection. Prolonged solder reflow may induce excessive leaching of the thick film conductor on the resistor.
- Flangeless devices are compatible with most solders designed for attachment to silver for BeO parts and Tin over Nickel for AlN parts. The solder used to mount flangeless devices should be chosen for individual application and environmental conditions.
- Heat must be carried away by the mounting surface/heat sink such that the power derating curve is not exceeded.
- Solder leads to RF lines using lead free or lead containing solder alloy with appropriate flux.
- Resistors and attenuators have two leads available, terminations have one lead available and the other lead is internally attached directly to ground.
- Unless otherwise specified operating temperature is -55°C to +150°C base plate, non-condensing. 100% of rated power -55°C to +100°C base plate derated linearly to 0% at +150°C.

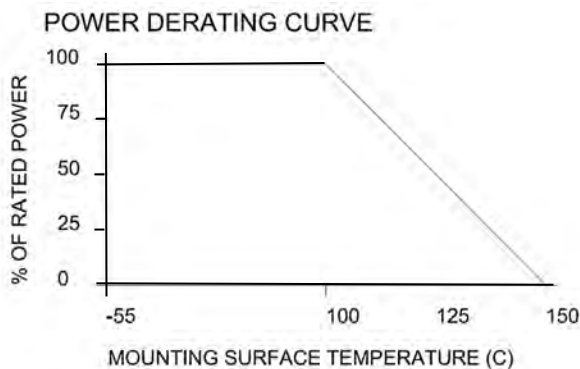

## IPP High Power Resistive Products Application Notes

- **Resistance Tolerance:** ±5% standard and ±2% available
- **Resistance Range:** 0.5 to 20K Ohm available, 50 and 100 Ohms are standard
- **Temperature Coefficient of Resistance (TCR):** ±125 ppm/°C

### ❖ Package Styles

- In general there are two package styles, flanged and flangeless. Flanged parts are mounted to the heat sink using screw fasteners and flangeless parts are designed to be soldered directly to the heat sink.

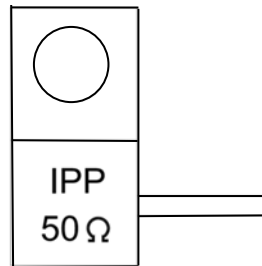

**Flanged**

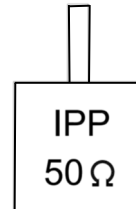

**Flangeless**

### ❖ Flange Resistor, Terminations, Attenuator Materials

- **Flange Material:** Nickel plate over Copper
- **Resistor Material:** Ruthenium based thick film
- **Lid Material:** Alumina or epoxy
- **Lead Material:** 99.99% Silver, 0.005" thick

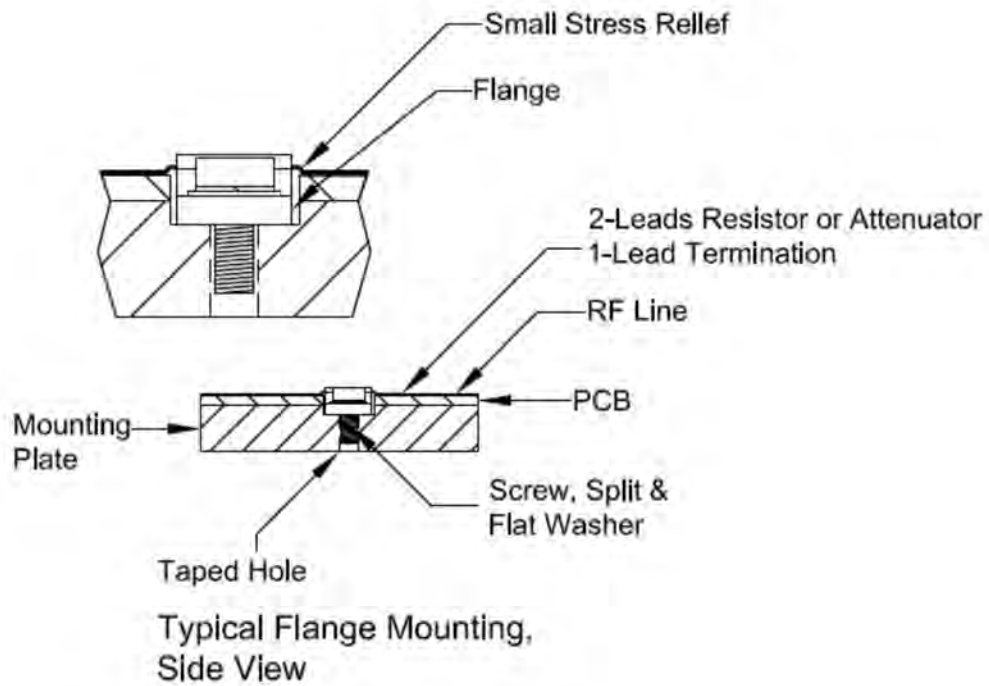

## IPP High Power Resistive Products Application Notes

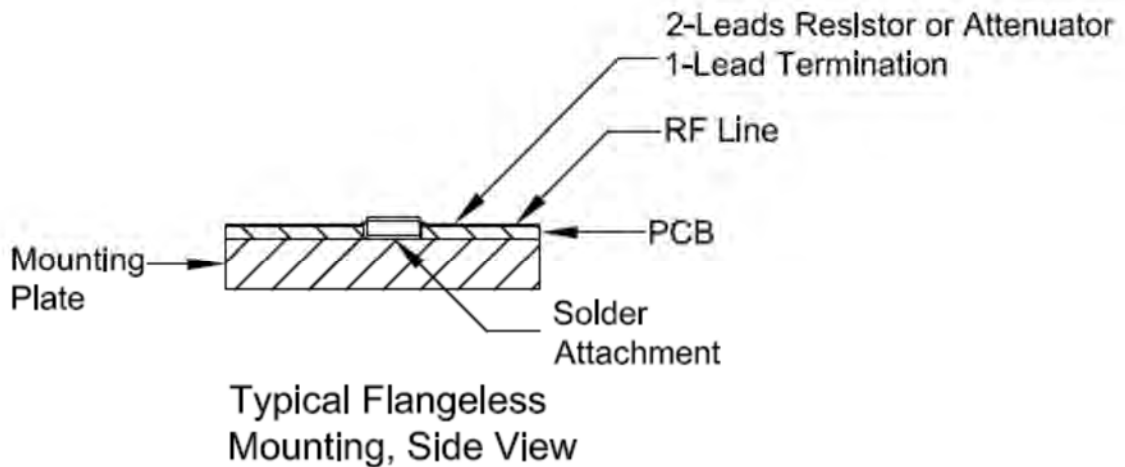

### Electrical Specifications

❖ **VSWR (Voltage Standing Wave Ratio)**

- The voltage standing wave ratio is a measure of how well a load is impedance-matched to a source. The value of VSWR is always expressed as a ratio with 1 in the denominator (2:1, 3:1, 10:1, etc.) It is a scalar measurement only (no angle). A perfect impedance match corresponds to a VSWR 1:1 meaning you will get all the power from source to load.

- $VSWR (\sigma) = V_{max}/V_{min}$