

# IPP Balun, SMD, 180° Transformer Application Note

## ❖ General Notes:

- o Data and specifications apply when part is mounted in IPP test fixture and terminated into 50 Ohms with >30dB return loss.
- o Keep unclad channel between RF port contact pads and ground plane clean for high peak power applications to prevent voltage arcing.
- o To ensure proper grounding and heat-sinking the bottom ground plane surface of balun must lay flat on mounting surface with good solder contact.
- o Assure good solder attach of the RF port pads to the RF pcb 50 ohm and 25 Ohm lines using a low temperature lead free or Sn63 solder alloy.
- o Operating temperature is -55°C to +85°C base plate, non-condensing.
- o Storage Temperature is 10°C to 60°C. The moisture sensitivity level is 1. Normal precautions should be taken to prevent surface oxidation.

## Input Output Relationships for -3dB, 180° Balun's

INPUT	OUTPUT	
J1	J2	J3
	-3dB <0°	-3dB <180°

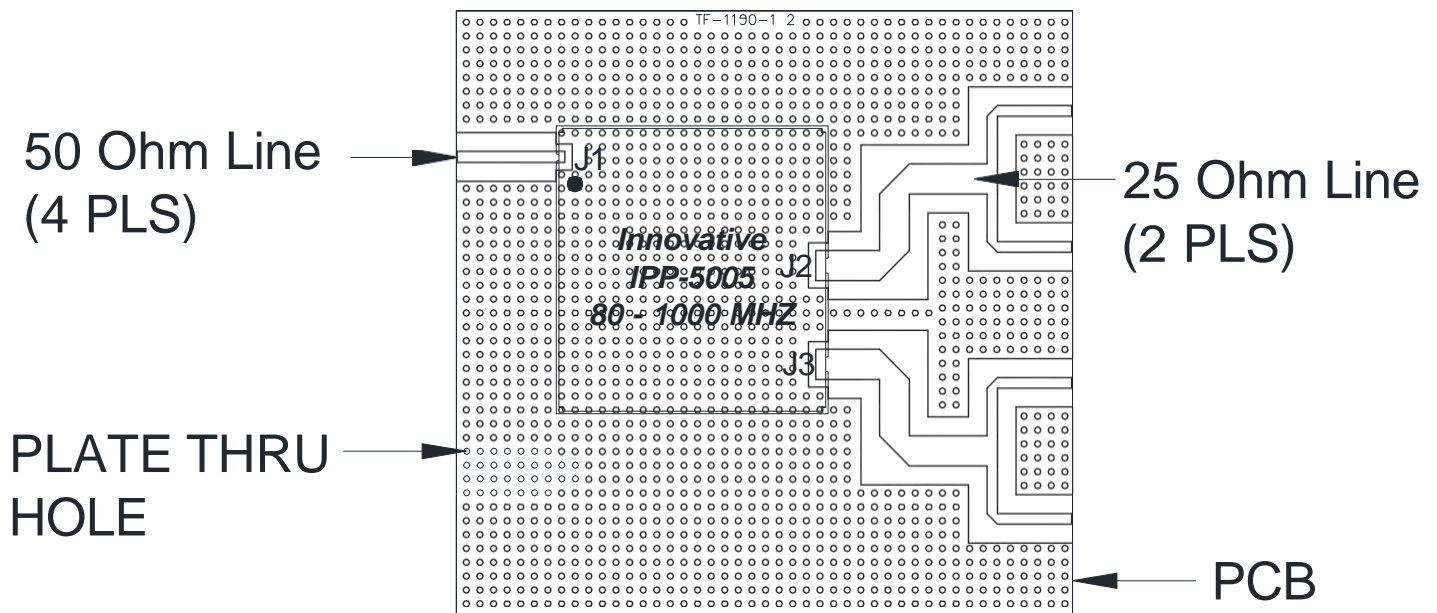

IPP Balun Test Fixture

## Electrical Specifications

### ❖ VSWR (Voltage Standing Wave Ratio)

- The voltage standing wave ratio is a measure of how well a load is impedance-matched to a source. The value of VSWR is always expressed as a ratio with 1 in the denominator (2:1, 3:1, 10:1, etc.) It is a scalar measurement only (no angle). A perfect impedance match corresponds to a VSWR 1:1 meaning you will get all the power from source to load.

- $VSWR (\sigma) = V_{max}/V_{min}$

### ❖ Insertion Loss (IL)

- The insertion loss is the amount of power (P) lost when transmitted through the balun from the input port to the output ports.

- $IS(dB) = 10\text{Log}(P_{inJ1}/(P_{outJ2}+P_{outJ3}))$

### ❖ Amplitude Balance (AB)

- The amplitude balance is the difference in the power levels at any given frequency for the same input level when measured at the two output ports.

- $AB(dB) = |10\text{Log}(P_{outJ2}/P_{outJ3})|$

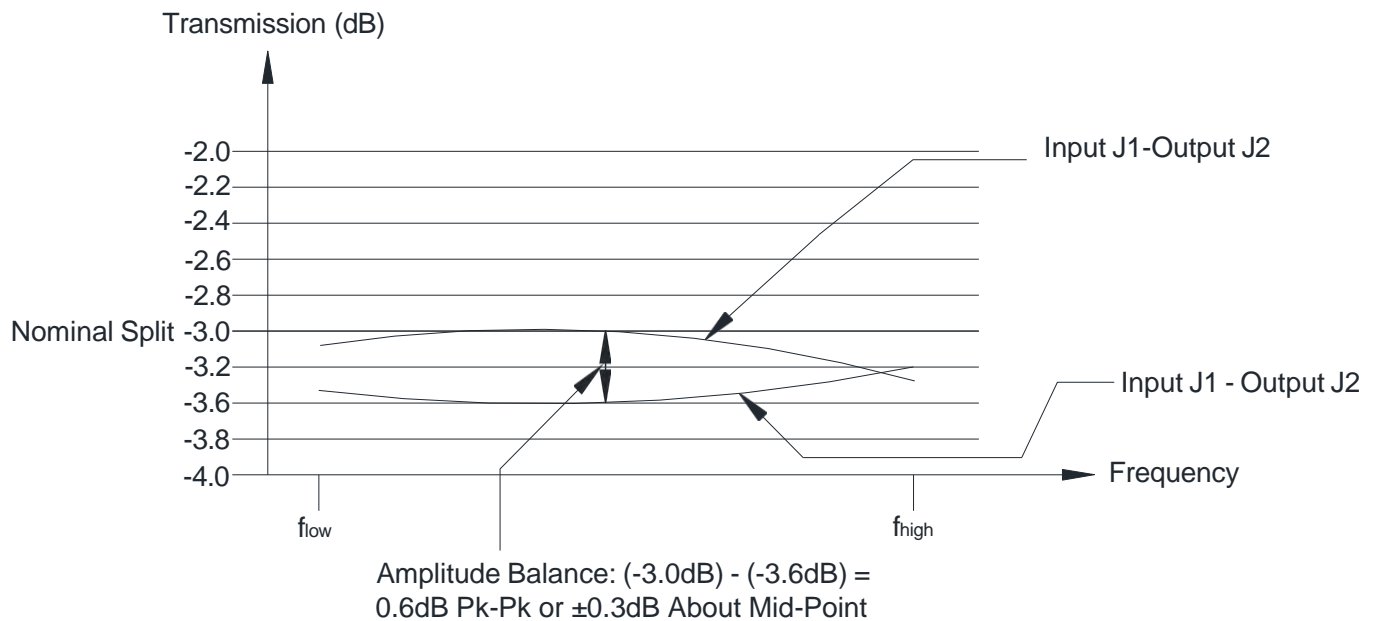

## Typical Amplitude Balance Responce

### ❖ Phase Balance (PB)

- The phase balance is the difference in phase angle between the power at port J2 and the power at port J3. The nominal difference being  $180^\circ$ .

- $PB(^\circ) = \angle P_{J2} - \angle P_{J3}$

### ❖ Power (P)

- The maximum total input power is the sum of the input power at each port.

- $P_{\text{total Max}} = P_{J1} + P_{J2} + P_{J3}$

### ❖ Port Impedance

- The Port impedances referenced to ground are as follows.
  - J1=50 Ohms, J2&J3=25 Ohms

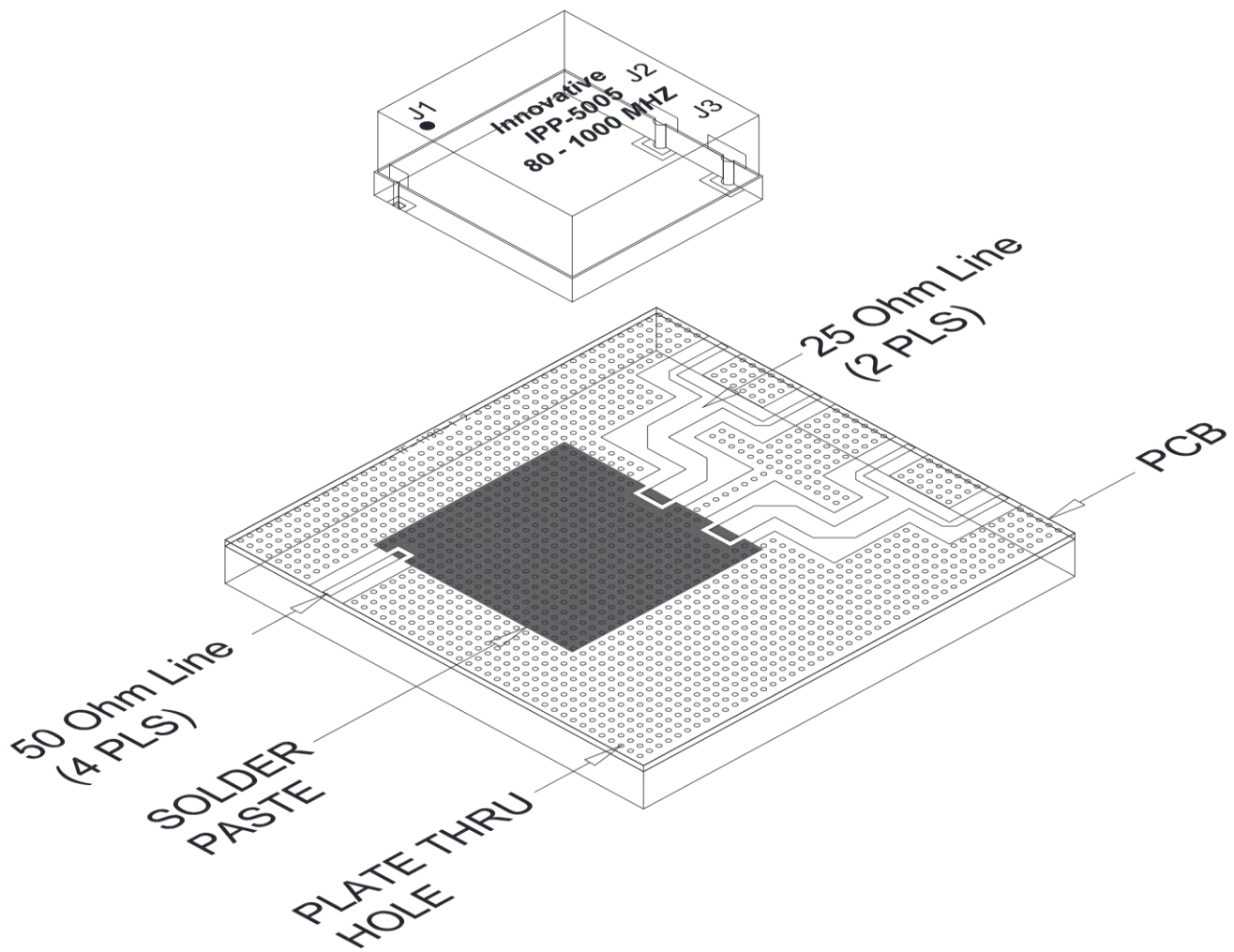

## SMD Balun Mounting

### ❖ Mounting, General

- The baluns are designed to be surface mounted to standard types of RF pcbs using tin-lead or lead-free solder. Do not exceed the installation temperature noted on the parts outline drawing. The Balun's are finished in RoHS Tin.
- For best performance the ground area of the balun should be fully soldered to the pcb ground. The pcb should have sufficient plated thru holes to provide a good, low inductance ground to the balun while also providing a low thermal resistance to the heat sink.
- 50 Ohm and 25 Ohm lines are required to bring the RF signals to and from the balun's port solder pads. Do not allow the 50 Ohm and 25 Ohm lines to encroach into the air gap between the balun's RF port pads and the ground plane as this will reduce the breakdown voltage.
- Solder paste should be applied to the pcb using a stencil or dispensing gun. The solder paste should cover the complete balun

ground plane area as well as the RF port pad area where the balun interfaces with the pcb.

- o Placement of the balun into the solder paste can be done by hand or pick and place machine. Care should be taken to place the balun as close to the final required alignment as possible. Misalignment of the balun after solder reflow can result in RF shorts or reduced performance.
- o The balun's are tested in IPP test fixtures. Use of pcbs other than what is used on the IPP test fixture is allowed however some minor matching of the 50 Ohm and 25 Ohm lines may be required to achieve the best performance.

### SN63 Solder Reflow Profile

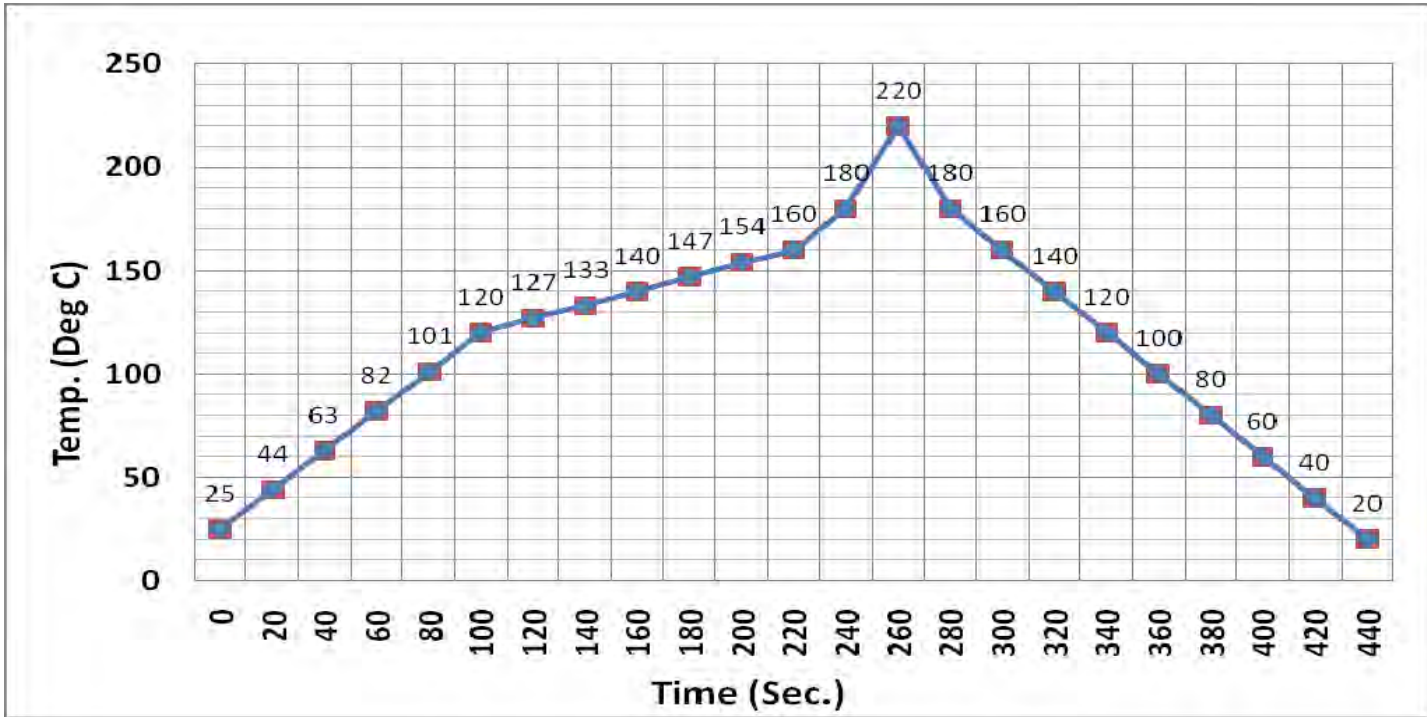

### Lead Free Solder Reflow Profile

